

# UP 111

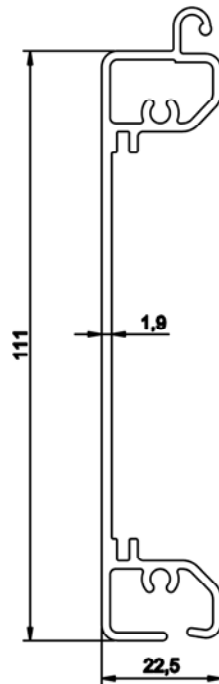
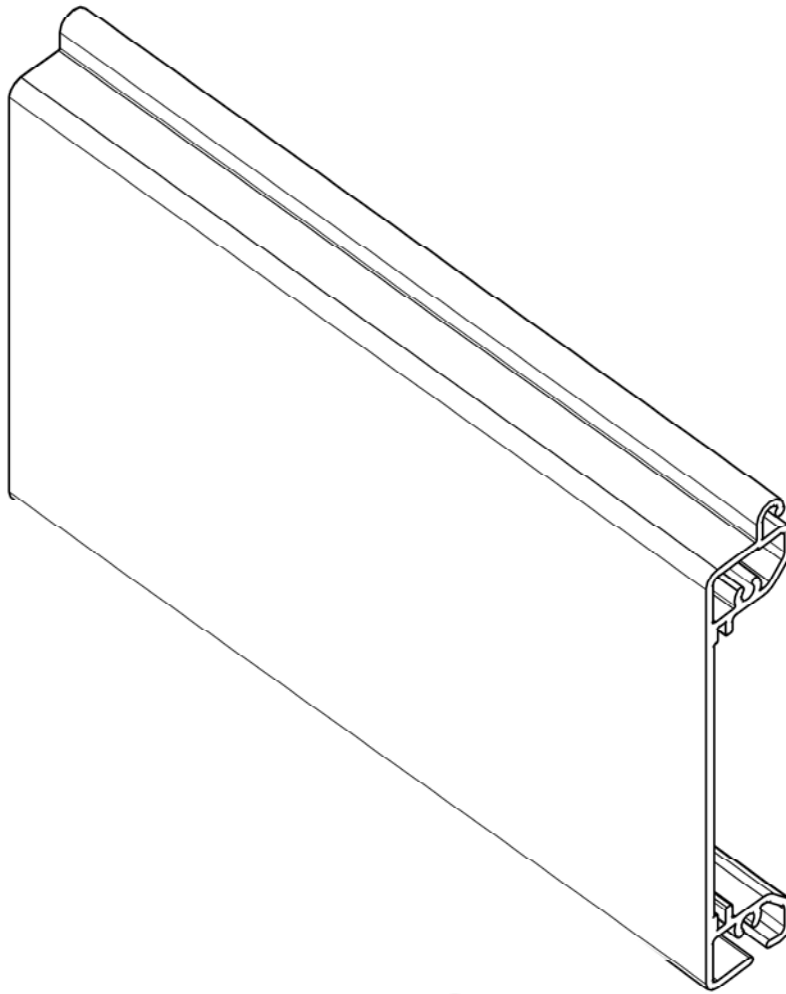

**PESO DE LA LAMA EXTRUSIONADO UP-111 CIEGO**

ANODIZADO	10,080 KG/M2	MATERIAL: ALUMINIO	LAMAS POR METRO: 9M	
LACADO	10,125 KG/M2	ACABADO: ANODIZADO / LACADO	ANCHO MÁXIMO ACONSEJADO: 12M	
			ALTO MÁXIMO ACONSEJADO: 10M	